



SERVICE MANUAL

INTRODUCTION

The gasoline engine industry's universal acceptance of Tillotson's original diaphragm carburetor has resulted in the development, by Tillotson engineers, of the "HL" Series carburetor.

Designed with a minimum of parts, this lightweight, compact carburetor includes an integral fuel pump and filter in one small unit. The all position mounting feature allows a wide range of possible applications.

Information contained in the following pages is presented as an aid to understanding construction, operation and servicing of the "HL" series carburetor.

HL SCHEMATIC

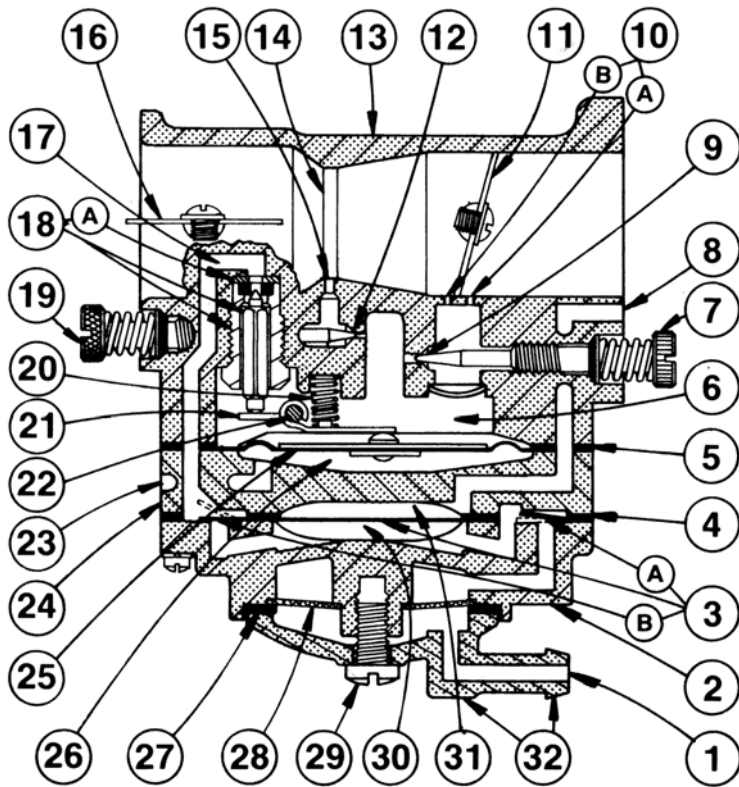

- 1. Fuel Inlet
- 2. Fuel Pump Body
- 3. Fuel Pump Diaphragm
- 3A. Diaphragm Pump Inlet Valve
- 3B. Diaphragm Pump Outlet Valve
- 4. Fuel Pump Gasket
- 5. Diaphragm Cover Gasket
- 6. Metering Chamber
- 7. Idle Adjustment Screw
- 8. Impulse Channel
- 9. Idle Fuel Adjustment Orifice
- 10A. Primary Idle Discharge Port
- 10B. Secondary Idle Discharge Port
- 11. Throttle Shutter
- 12. Main Fuel Adjustment Orifice
- 13. Body
- 14. Venturi
- 15. Main Fuel Discharge Port
- 16. Choke Shutter
- 17. Fuel Inlet Supply Channel
- 18. Inlet Needle & Seat
- 18A. Copper Gasket
- 19. Main Adjustment Screw
- 20. Inlet Tension Spring
- 21. Inlet Control Lever
- 22. Fulcrum Pin
- 23. Atmospheric Vent Hole
- 24. Diaphragm Cover
- 25. Diaphragm
- 26. Atmospheric Chamber
- 27. Strainer Gasket
- 28. Fuel Inlet Screen
- 29. Strainer Cover Retaining Screw
- 30. Fuel Chamber
- 31. Pulse Chamber
- 32. Strainer Cover

Note: On some models a one piece Idle Adjustment Screw (ref. 7) & Main Adjustment Screw (ref. 19) with rubberized "O" ring attached (not illustrated above) are used

CONSTRUCTION DATA

The "HL" series carburetor is a lightweight, aluminium die cast carburetor composed of four basic parts: metering body, main diaphragm cover plate, fuel pump body and strainer cover. The diaphragm carburetor incorporates many of the same type components found in float type carburetor: choke, throttle, idle and main mixture adjustment screws, idle speed screw and inlet needle and seat.

Two styles of main and idle adjustment screws are available: "O" ring type and spring loaded packing type. Both types are designed to perform the dual purpose of sealing the metering chamber and providing adjustment screw friction.

A special insert, housed in a brass cage, forms a seat for the inlet needle. An inlet tension spring exerts a pre-determined force on the inlet control lever, which holds the needle on its seat.

A metering diaphragm is subjected to engine suction on the metering chamber side and atmospheric pressure on the vented side. Atmospheric pressure on the vented side pushes the diaphragm toward the inlet control lever, opening the inlet needle to allow fuel to enter the metering chamber, from which it is then delivered into the mixing passages.

The vented side of the metering diaphragm may be vented either directly to the atmosphere, or in the case of the balanced carburetor, may be balanced (internally vented) to the choke bore. The balanced type can be recognised by a brass tube in the choke bore which is connected internally to the vented side of the diaphragm. The purpose of internal balance is to offset the enriching or choking effect of a partially dirty air cleaner.

Some carburetor metering systems include a ball check type main nozzle. These can be identified by the brass cage located in the venturi choke band of the body casting. The ball check valve allows fuel to flow into the mixing passage and prevents air from flowing into the metering chamber.

The movement of the pump diaphragm draws fuel into the fuel chamber and a reverse movement of the diaphragm forces fuel out of the fuel chamber through the inlet needle and seat into the metering chamber. Movement is caused by pulsation from the engine, acting on the diaphragm.

A plastic turret inlet connection is the cover to the fuel strainer section of the carburetor and can be rotated 360 degrees for any required fuel connection location. The strainer consists of a fine mesh screen to insure clean fuel supply to the metering section of the carburetor.

ADJUSTMENT INSTRUCTIONS

To properly adjust carburetor for best performance the engine must be thoroughly warm.

INITIAL ADJUSTMENTS:

To start a cold engine, first carefully close, by turning clockwise, both idle and main adjustment screws. Open main adjustment screw counter clockwise approximately one and one quarter ($1\frac{1}{4}$) turns. Open idle adjustment screw three quarters ($\frac{3}{4}$) turn. Back idle speed regulating screw off its contact with throttle stop lever, then turn it inward about one (1) full turn so as to slightly open throttle shutter.

Open fuel line shut off valve, close choke shutter, partly open throttle shutter and pull starting cord. When engine fires, open choke shutter slightly and idle the engine. Do not race engine. Then as engine warms, open choke shutter. To start a warm engine it should only be necessary to pull starting cord, if the carburetor is properly adjusted.

FINAL ADJUSTMENTS:

Completely close throttle shutter and readjust idle speed regulating screw so engine idle speed is approximately 1200 RPM for lawn mowers – 2000 to 2500 RPM for chain saws – then slowly readjust idle adjustment screw to obtain smooth and even engine performance. Poor acceleration may result from setting the idle mixture too lean.

DO NOT FORCE ADJUSTMENTS INTO SEATS!

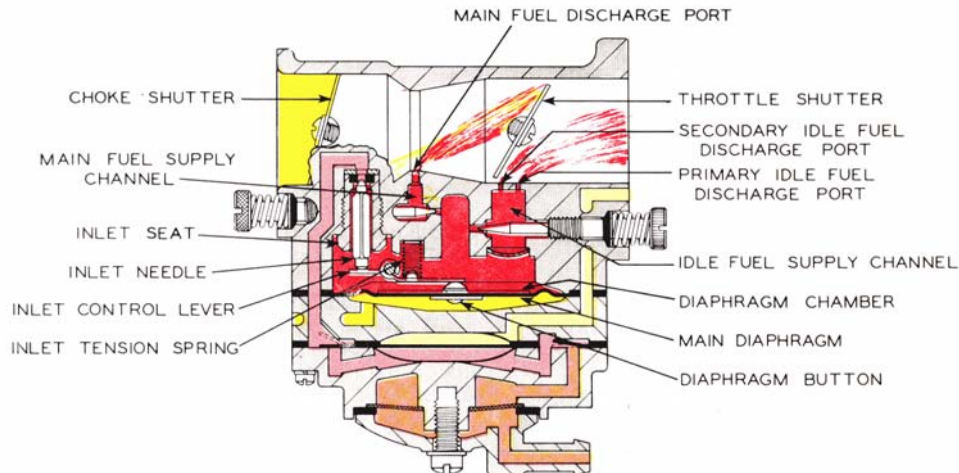

STARTING CHOKE OPERATION

Starting an engine with the "HL" Carburetor involves the same methods that are used in a conventional float feed carburetor. However, since a diaphragm carburetor does not have the advantage of a great reservoir of fuel upon which to operate, the technique changes somewhat.

When starting a cold engine, place the choke shutter in the closed position and throttle shutter in a cracked or open position. Several pulls on the starter may be needed to raise the fuel pressure to the required amount. As the engine is pulled through with the choke in closed position, engine suction will be transmitted to the diaphragm fuel chamber through both primary and secondary idle discharge parts as well as the main fuel discharge part, creating a low pressure area on the fuel side of the main diaphragm. Atmospheric air pressure on the opposite side will force the main diaphragm upward causing the diaphragm button to depress the inlet control lever, overcoming inlet tension spring pressure, permitting fuel to enter through the inlet seat, by forcing inlet needle off its seat contact, then into the fuel chamber side of main diaphragm, up through the idle and main fuel supply orifices and channels, and out the discharge parts to the engine.

In starting an engine that has been idle and not running for more than an hour, it will be necessary to operate and manoeuvre the choking mechanism for approximately three (3) to ten (10) seconds depending on how cold the engine has become. The length of time spent warming the engine is only necessary to the extent that the engine can be made to idle, accelerate and run satisfactorily under wide open throttle conditions.

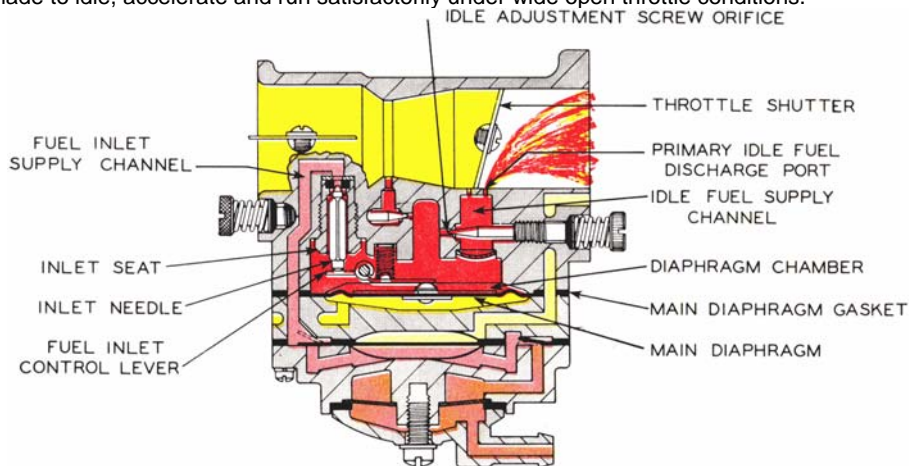

IDLING OPERATION

When engine is idling, throttle shutter is in a partially cracked position. Engine suction is transmitted through the primary idle fuel discharge port to the fuel chamber side of main diaphragm via the idle fuel supply channel. Again, the main diaphragm is forced upward by atmospheric pressure, depressing the inlet control lever overcoming inlet tension spring pressure and permitting fuel to enter through inlet seat, by forcing inlet needle off its seat contact, and filling the fuel chamber side of main diaphragm. The fuel is then drawn up through idle fuel adjustment orifice and delivered to the engine through primary idle discharge port.

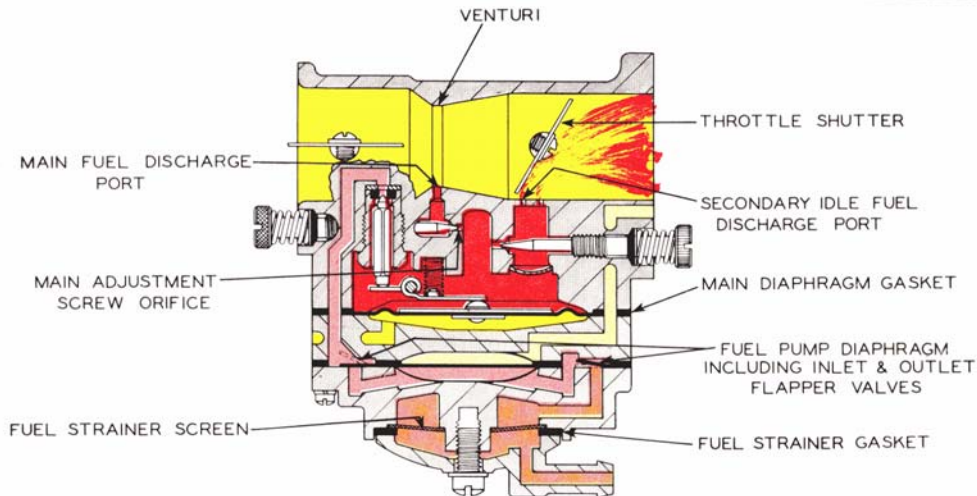

INTERMEDIATE OPERATION

Fuel is delivered into and through the carburetor in the same manner as when the engine is idling. However, as the throttle opens and engine speed increases, more fuel is demanded from the carburetor and supplied to the engine by valving in the secondary idle discharge port located immediately behind the throttle shutter. As the throttle shutter continues to open and engine speed increases, the velocity of air through the venturi creates a low-pressure area at the venturi throat and diminishes the suction on engine side of the throttle shutter. When the pressure at the venturi throat is less than existing within main diaphragm fuel chamber, fuel is drawn up through main fuel adjustment orifice and out main fuel discharge port into air stream entering engine intake.

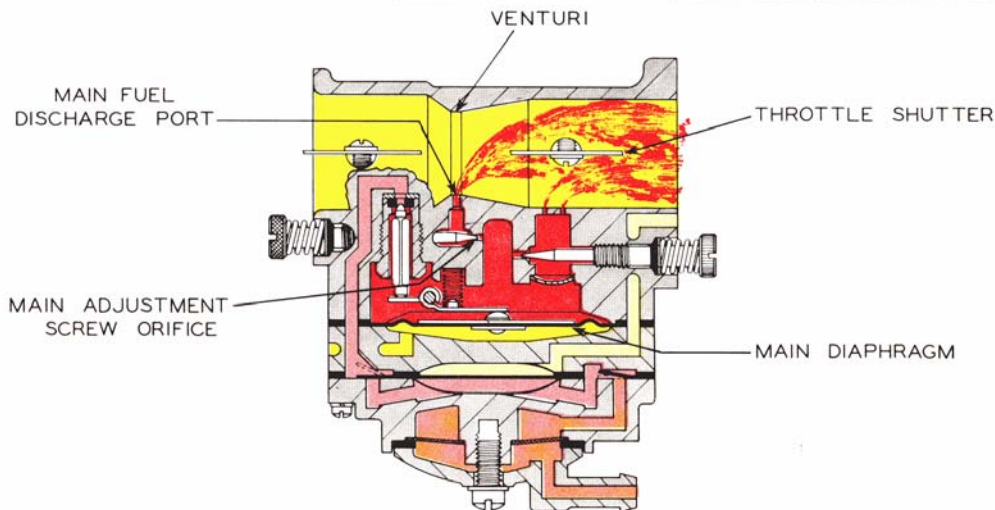

HIGH SPEED OPERATION

As the throttle shutter progressively opens from intermediate position to full open position, the air velocity through the venturi increases and fuel is metered up through main fuel adjustment orifice and main fuel discharge port in accordance with the power requirements of the engine. The action of the main diaphragm is the same as previously described with suction required to operate the diaphragm being transmitted through the main fuel discharge port.

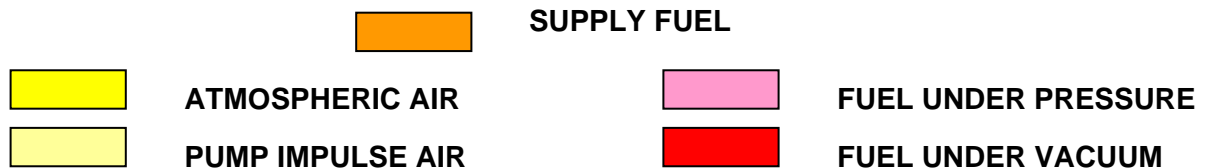

HOW TO DISASSEMBLE FOR CLEANING AND REPAIR

The model "HL" carburetor can be cleaned under adverse conditions - working on a clean surface with a minimum of tools. Before disassembling carburetor it is **IMPERATIVE** to flush it clean of sawdust and dirt by pouring gasoline over it and tools.

1. Remove strainer cover retaining screw and plastic cover.
2. Remove strainer cover gasket and strainer screen.
3. Remove screws and fuel pump body.
4. Remove fuel pump diaphragm and gasket.
5. Remove main diaphragm cover plate.
6. Remove main diaphragm.
7. Remove main diaphragm gasket.
8. Remove inlet control lever fulcrum pin, lever and tension spring.
9. Remove inlet needle.
10. With a thin wall 5/16" Hex socket carefully remove the inlet seat. Remove inlet seat gasket. When reinstalling seat, tighten only from 25-35 inch-pounds or 34Kg-Cm.

1. Remove idle and main adjustment screws.
2. When reinstalling "O" ring type adjustment screws, lubricate with #30 SAE oil to prevent seizing. Packing spring type adjustments to not require lubrication.
3. The ball check type main nozzle can be removed by tapping it out of the body casting into the venturi with a small punch. A replacement ball check nozzle should be pressed into the casting with the cross holes in line with the main adjustment needle. The brass cage should be pressed flush with the metering chamber casting.

Before reassembling the carburetor (in reverse order as outlined above), wash ALL component parts in clean gasoline and blow off with compressed air. The channels in the metering body should be cleaned by blowing through the idle and main adjusting orifices.

All fuel passages in the three castings should be cleaned with compressed air. Do not clean orifices or passages with wires or drills as this might cause damage and incorrect operation of the carburetor.

SERVICE HINTS

When reassembling the inlet control lever and spring, care should be taken to see that the spring rests in the well of the metering body and locates on the dimple of the inlet control lever, (as illustrated below).

CAUTION: Do not stretch spring.

Inlet control lever is properly set when flush with floor of diaphragm chamber.

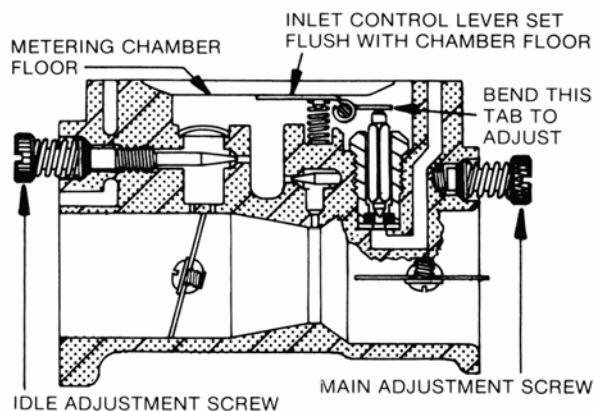

Be certain main diaphragm, gasket and cover casting are carefully fitted over the three small pins cast in rim at bottom of metering body; also the fuel pump gasket, diaphragm and fuel pump body, over similar pins at bottom rim of main diaphragm cover casting. Evenly tighten fuel pump body retaining screws to insure complete seal of casting separations at both diaphragms.

Frequent cleaning or replacement of fuel strainer screen will aid satisfactory operation of the carburetor.

CAUTION: Under extreme conditions of clogged idle fuel supply channel and discharge ports, it may be necessary to remove the channel welch plug. If so, it must be very carefully done in following manner:

1. Drill a 1/8" diameter hole through the 3/8" diameter welch plug. This hole should just break through the welch plug. Deeper drilling will seriously damage the body casting and its discharge ports located close behind the welch plug. On some models an additional smaller 1/4" diameter channel welch plug is used. It is not necessary to remove this plug.
2. Carefully pry out welch plug, then clean discharge ports and cross channels. Now install new part 02531 (3/8" diameter, 1/32" thick) welch plug by placing it in casting shoulder, convex side upward; then flatten to a tight fit with a 5/16" diameter flat end tool.

TROUBLE SHOOTING

Carburetor Floods

- | | |
|--|--|
| 1. Dirt or foreign particles preventing inlet needle from seating. | Remove, clean and replace. |
| 2. Diaphragm lever spring not seated on lever dimple. | Remove, lever and reinstall |
| 3. Diaphragm improperly installed in carburetor. | Replace diaphragm or correct installation. |

Engine will Not Accelerate.

- | | |
|--|---|
| 1. Idle adjusting screw set too lean. | Enrich idle adjustment |
| 2. Incorrect setting on diaphragm lever. | Reset |
| 3. Diaphragm cover plate loose. | Tighten |
| 4. Diaphragm gasket leaking. | Replace |
| 5. Main fuel orifice plugged. | Remove diaphragm cover, diaphragm lever and main adjusting screw. Clean out orifice by blowing through main adjustment threaded hole. |

Engine Will Not Idle

- | | |
|--|--|
| 1. Incorrect idle adjustment. | Reset to best idle. |
| 2. Idle discharge ports or channels clogged. | Blow out with compressed air, or, if compressed air is not available, clean and flush with gasoline. |
| 3. Diaphragm lever set incorrectly. | Reset diaphragm lever so it is flush with the floor of the diaphragm chamber. |
| 4. Throttle shutter cocked in the throttle bore causing fast idle. | Reset |
| 5. Dirt nozzle check valve. | Clean or replace |
| 6. Welch plug covering the idle discharge ports does not seal. This causes the engine to idle with idle adjustment shut off. | Replace welch plug, following instructions outlined in service hints. |

Engine Runs Out Lean

- | | |
|--|-------------------------------------|
| 1. Tank vent not operating correctly. | Clean, if possible, or replace |
| 2. Leak in fuel system from tank to pump | Tighten or replace fittings or line |
| 3. Ruptured fuel pump diaphragm. | Replace |
| 4. Main fuel orifice plugged. | Clean |

Carburetor Runs Rich With Main Adjustment Shut Off

- | | |
|--|------------------------------|
| 1. The 1/8 " diameter nozzle channel plug, or nozzle check valve cage, is not sealing. | Install new plug or new cage |
|--|------------------------------|

NOTE:IN MAKING CARBURETOR ADJUSTMENTS TURN ADJUSTMENTS CAREFULLY AND GENTLY -DO NOT RAM ADJUSTMENTS INTO SEATS.

Set engine idling speed in accordance with engine manufacturer's recommendation.

TROUBLE SHOOTING

Be sure all Pump Body Screws are tight to insure perfect seal at the parting surfaces.

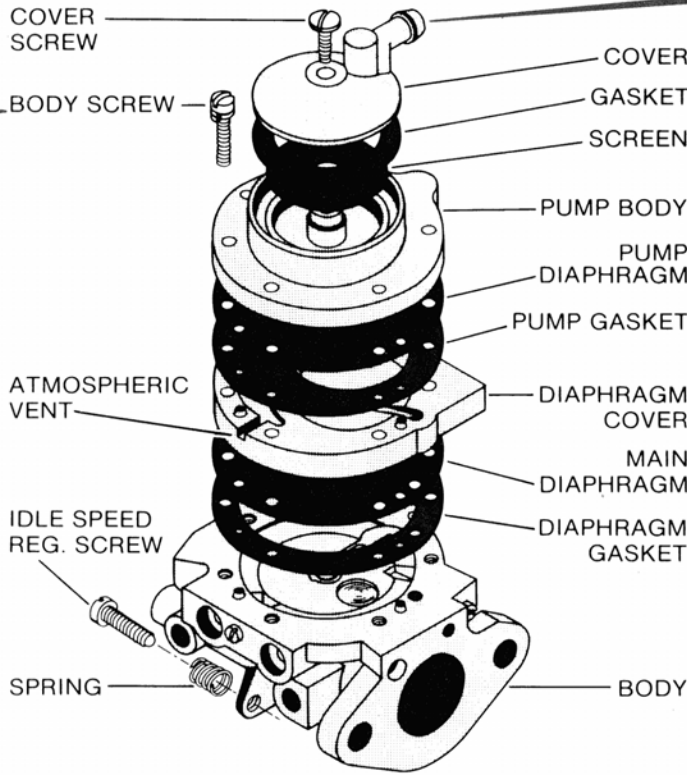

Fuel Inlet Line must be tight.

Remove Cover Screw, Cover, Gasket and screen. Thoroughly clean Screen with clean gasoline or by blowing through with compressed air. Install Screen next to Pump Body casting, then gasket. Hold Cover in place and tighten Cover Screw.

Pump Gasket and Pump Diaphragm must locate on cast pins, at underside of Diaphragm Cover rim, to insure correct installation and operation. Pump Diaphragm must be clean and free of breaks or punctures.

Diaphragm Gasket, Main Diaphragm and Diaphragm Cover Casting, must locate on cast pins, at the body rim, to insure correct installation and operation. Main Diaphragm must be clean and free of breaks or punctures. Its metal disc must not become bent and should always retain tight fit to rubberized body section.

Press in place flush with body casting.

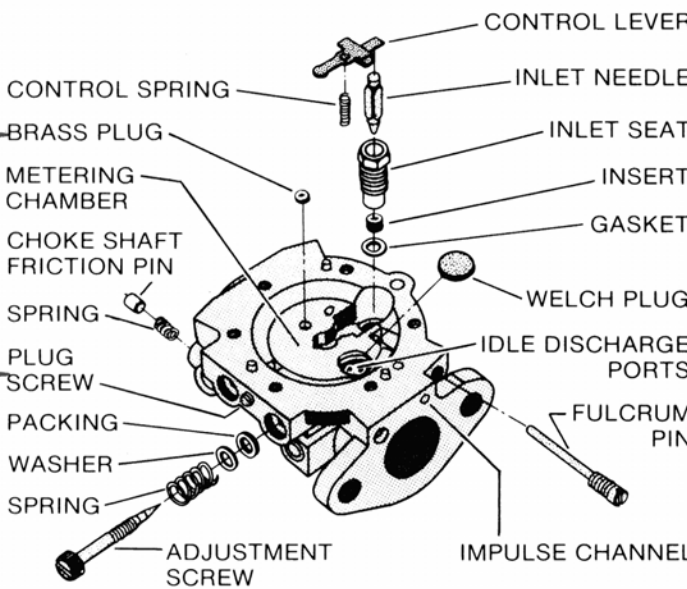

Control Lever must rotate freely on Fulcrum Pin. Set Control Lever flush with floor of metering chamber.

To inspect and clean Inlet Needle and Seat, first remove Fulcrum Pin and Control Lever, then inlet needle. The Inlet Seat can now be carefully removed with a 5/16" hex socket wrench.

CAUTION: If Inlet Seat is not handled with care the small Insert may fall out unnoticed. Remove Gasket and replace with new one before reinstalling Inlet Needle and Seat by reversing above procedure.

Welch Plug must seal tightly.

Idle Discharge Ports must be open.

Drain Plug Screw must seal tightly.